

System and Architecture Design for Smart Helmet using NLP and Peripheral Sensor System for Accident Avoidance.

Mr. Virendra Vishnu Shinde
Computer Department Indira College of Engineering and Management
Pune, Maharashtra, India

Mr. Akash Singh
Computer Department
Indira College of Engineering and Management
Pune, Maharashtra, India

Mr. Tarandeep Singh Mandhiratta
Computer Department
Indira College of Engineering and Management
Pune, Maharashtra, India

Dr. Poornashankar
Computer Department
Indira College of Engineering and Management
Pune, Maharashtra, India

Abstract— Presented paper discusses the architecture design and component requirement of the project ‘smart helmet’. The proposed system, with combination of the features of a mobile phone and safety of a helmet, aims to eliminate the negligence of safety while driving a motor-cycle and use of mobile phones while driving which causes distraction that may result in an accident. The peripheral sensors have been mentioned along with their description. UML diagrams are used to depict the flow of project and interacting components. Proper hardware and software requirements are stated, these choices are made according to the overall feasibility of the project.

Keywords— Navigation, Mobile Functions, Safety, Good user experience, Helmet, Voice command, VUI.

I. INTRODUCTION

In today’s fast paced and exploring era, lot of people are relying on mobile devices for many tasks such as calling, message reading, navigation etc. It is worth mentioning, since the growth of many delivery services, be it in food delivery, couriers, appliances delivery, or any product delivery in general, industry has opened many job opportunities for delivery personnel. These people are responsible for proper and punctual delivery to the customer, and many of these are carried out through most accessible vehicle; “Bikes”. Also, it has been seen that over the years people are getting attracted towards the fad of journeying to distant places on bikes, and they are completely relied on mobile devices, major purpose being navigation. The biggest catch with using mobile or similar devices during driving is that, to look at the directions or to receive calls, texts, etc, the rider must stop their bike and look at the device and then continue riding. Sometimes they don’t even bother stopping and check their mobile device while riding the bike, which in many cases causes distraction and accidents. With the ever-growing danger of distracted driving related incidents, it became clear that we need a solution to this problem of distraction and time wastage, we

needed a solution that might help us use our mobile functions effectively, be less distracting and also will not require the rider to stop to check their device every time. Taking account of above problems, our goal was to increase safety for motorcyclists and prevent dangerous accidents, while still maintaining a good user experience. Whenever the safety of motorcyclists come into picture, the first thing that pops up in the mind is a “Helmet”. A protective shell that is meant to protect our head from potential injuries in any unfortunate incident. Many a times people find it tedious and clumsy to wear a helmet, jeopardizing their safety. Hence, came the idea of combining the mobile applications with the Helmet to have a hassle-free mobile system on voice command that will not cause any distractions and along with it will also propagate the use of helmet.

A. Motivation

With the ever-growing danger of distracted driving related incidents, there was seen a need for a solution to tackle this problem. Our goal is to increase safety for motorcyclists and prevent dangerous accidents, while still maintaining a good user experience.

B. Problem Definition

An accident is an unpredicted and unintentional event. Considering the alarming increase within the number of motor bike riders and therefore the number of accidents happening in our country, build a system to form the two-wheeler driving safer than before for the rider. Build an intuitive smart helmet to make a totally voice controlled interactive system to help a motorcyclist on the road, while leaving the opposite four senses to specialise in the safety of the user without impeding the sense of sight.

II. RELATED WORK

Keeping in mind the safety of bike riders, helmets are being constantly improved to serve their purpose better. With time, many

features have been added to the helmets to increase their functionality. Many companies have successfully tried and implemented various versions of helmet having different abilities and functionality along with their basic agenda of protecting the bike rider. Most prominent work is seen in the 'Green Stone G6' Helmet which features dual Bluetooth connectivity with few operations of voice commands. Most promising systems having potential to grow are either not easily available in the market or too expensive to be affordable due to the components used. There are systems still in development who claim they will acquire AR functionality in the coming future to give full HUD (Heads-Up-Display) for the rider.

Talking about HUD, Google glasses also come into picture. It was launched in May of 2014 by Google. 'Google glass' is small, light-weight, wearable computer that has the ability to display functions on the transparent screen of the glasses. It also gives the wearer the ability to access hands-free navigation [1]. However, while driving it is found that, wearing them becomes a hindrance and sometimes cause distraction, impeding the sense of sight which might result in accident.

NLP is used in various domains as means of executing different algorithms for recognizing text and text patterns, like generating SQL queries from natural spoken language [2] or an identifying and extracting unique or constantly used key phrases [3] to help build a better neural network.

To prevent accidents, accident detection is most important task, in many systems vibration sensors are used widely as means of detecting vibrations as a result of the impact from the accidents, which can be taken a notch above by using IMU (Inertial Measuring Unit) [4][5].

Other safety feature involves the confirmation that the user is wearing the helmet. To exercise this, RFID tag is used, which is commonly used for detecting or identifying various objects connected through RFID tags [6]. Due to its usability RFID has been subjected to various upgrades which involves development of Wideband and long range, radiation efficient RFID tag [7][8].

Alcohol sensors are widely used sensors for detecting alcohol, used by various authorities as well as in various systems, like car locking system which locks the car if alcohol content is found in the user's body, it is portable as well as highly compatible with many other systems [9][10].

III. PROPOSED SYSTEM

The proposed system utilises the combination of various concepts such as NLP and embedded programming along with the use of various sensors such as alcohol sensor, RFID sensor, vibration sensor, microphone, speaker, buzzer to enhance the natural ability of the helmet of protecting the bike rider. It uses cost efficient, yet robust and easily available components as an alternative for the priced one so that the product could become affordable for everyone.

A. Project Flow

In this project contains two module one helmet section and vehicle section. In helmet section, it contains ear lobe

(switch) and alcohol sensor if alcohol is not detected and switch is on then send a rf data to turn on the ignition in the vehicle (motor on) else relay is off that means ignition off (when alcohol detected display alcohol detected and buzzer on)

In the vehicle section if the above two condition are matched only then turn on motor and display helmet worn. If vibration sensor picks up reading higher than the threshold than accident has occurred, quickly trigger the buzzer to let the bystanders know, and it also uses google account settings to let others know the current location of the user.

The proposed system utilises NLP for implementing the VUI which gives the wearer the ability to interact with the helmet hands-free and issue voice commands to 'Navigate' to certain destination, 'Send' or 'Read' recent messages or mails, 'Make Call' to the said contact.

IV. SYSTEM REQUIREMENTS

A. Software requirement

1. NLP (Natural Language Processing)

Natural Language Processing or NLP in the field of computer science is a branch that is concerned with the human computer interaction via natural language, i.e. to program systems to analyse and process natural language data. Developed by Google, GTTS (Google Text to Speech), is an application capable of reading screen developed for the Android OS. It supports applications to read the text displayed on the screen. It supports many languages. A text-to-speech system has the ability to convert a normal (human) language text into speech. In the said system, GTTS is used as a supporting application to read out recent text messages or any mails hence received on the mobile device, and also to process voice commands thus issued by the user. Speech to text is a software technology which is capable of effective audio content recording and transcribing it into written words on a display destination. In the said system, it helps taking audio input from the user which is nothing but the

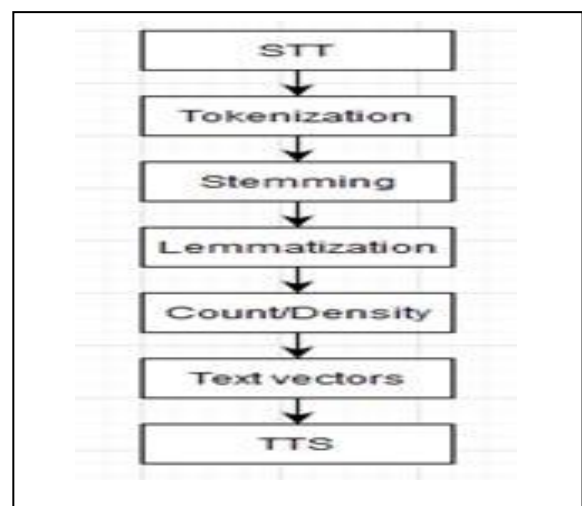

voice commands.

Fig.1 : NLP Flow Chart

1.1 Tokenization

In NLP, Tokenization is a common task which carries out the chopping of characters into pieces called 'tokens', discarding certain characters like punctuation simultaneously. Example: For the sentence like; "Hello friend, how are you.", tokenized output gives: ('Hello', 'friend', ',', 'how', 'are', 'you', '.'). An effective algorithm for information retrieval using tokenization is shown below [12];

1.1 Temming

In NLP, Stemming is a process of removing suffix from a word and reducing it to its root word. Example: "Flying" is a word and its suffix is "ing", if we remove "ing" from "Flying" then we will get base word or root word which is "Fly". At the basic level, Stemming is done using popular model 'n-gram model' which assigns probabilities to sentences and sequences of words [11]. It substantially describes Out of the times you saw the history 'h, how many times did the word 'w' follow it, i.e. $P(w|h)$.

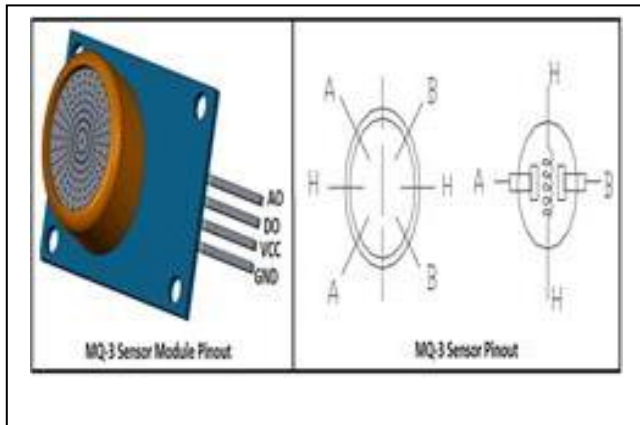

Fig. 2. Alcohol Sensor MQ3

1.2 Lemmatization

In general terms, Lemmatization refers to the use of vocabulary and morphological analysis of words, normally to remove inflections and return only the base word, known as 'lemma'. Example: If confronted with the token saw, stemming might return just 's', whereas lemmatization would attempt to return either 'see' or 'saw' depending on whether the use of the token was as a verb or a noun.

1.3 Text vectors

In NLP, it is a common practice to use pre-trained vector representation of words, so called embeddings. Word embedding are the representation of the implicit relationship between words that seems to be useful while training on data.

1.4 TTS (Text-to-Speech)

TTS or Text-to-speech is an application that is capable of converting displayed text into spoken word. It does it by analysing and processing the text using NLP, and then uses the Digital Signal Processing technology for the purpose of conversion of the processed text into speech representation.

B. Hardware requirement

1. Raspberry Pi

Raspberry Pi can be seen as small pocket-sized computer that can be plugged into any display device together with all the peripherals such as standard mouse, keyboard etc. It was designed to help students across the world learn about computers and coding in as minimal expenditure as possible. It is capable of handling most of the



Fig.3 Raspberry Pi

2. Vibration Sensor

Sensors having a keen ability to detect vibration or tilt in any system and record the readings hence acquired are called Vibration Sensors. The said system utilises the ability of the vibration sensor to detect accident scenario and work as a SOS system in case of emergency. SW-420 Vibration sensor is the sensor used in the said system

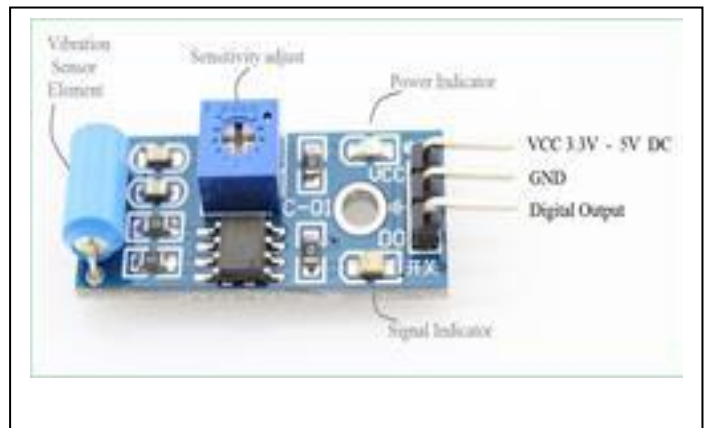

Fig. 4v SW-420 Vibration Sensor

3. Alcohol Sensor

Alcohol sensor is a sensor which is capable of detecting gas leakage. Due to its affinity of detecting various gaseous substances it is suitable for detecting alcohol in a human system which is detected through the breath of the user. Said system utilises the same property to detect alcohol levels in the body of bike rider.

4. RFID Sensor

Mostly used for projects such as IoT and access control system, RFID Sensors are the sensors which use electromagnetic fields to identify and track tags attached to various objects automatically. It utilises Radio-Frequency- Identification technology to do the same. In the said system RFID Sensor is used to detect whether

the rider is wearing the helmet or not else the vehicle will not start thus making it mandatory to carry the helmet every time.



Fig..5 RFID Sensor

5. Microcontroller

ATmega32A is a low power Microchip having high performance 8-bit AVR RISC based microcontroller having self-programming 32KB flash memory. It features 2KB SRAM, 1KB EEPROM 8 channel 10-bit A/D converter and JTAG interface for on-chip-debug.

V. OTHER SPECIFICATIONS

1. Advantages

- Lesser distraction while driving.
- Easy usage and hassle-free interface.

VI. DATABASE SPECIFICATION

1. Firebase

Firebase is a mobile and web development platform that has around 18 products which are used by various application from various origins . Firebase database provides a cloud- hosted Realtime NoSQL database used for storing and synching the data.

2.2. Safety

Safety being the main issue within the lives of these who ride bike, helmet may be a necessary accessory to hold around. Smart helmet being digitally sound and attractive at an equivalent time will soon become a trend among the bike riders round the world. It will create and increase awareness among people to use helmet whenever to make sure their safety whenever they ride bike. Smart helmet alongside providing all the mobile features also will look out of safety of the rider.

2.3. Feasibility

2.3.1 Technical Feasibility:

The planned system uses low-cost and open sourced elements, that are pronto out there inside the market. It uses a technology, which can simply be designed. therefore,

- Voice over interaction.
- Hands-off Navigation while riding bike.
- Hands-off Calling while riding.
- A trend to encourage the use of helmets while driving.
- Easy adaptable system, that can be applied to any helmet.
- Can help avoid collision via vibration sensor
- Can detect alcohol.
- Makes sure that the driver wears the helmet

2. Scope and Feasibility

2.1. Scope

Traffic jams in India are quite common and are so intense that it'll take hours to travel for miles. More over accidents occur by attending the calls while in driving. It is extremely difficult to seek out an individual where he met with an accident in remote areas. It is extremely difficult to navigate while driving the bike since it requires checking the phone constantly. To tackle these issues idea of creating a sensible helmet came into picture.

- Our smart helmet features a scope of usage in everyday lives of folk who use bikes.
- Common people that use motorcycles on day to day. It will prove more beneficial in the delivery service industry where the employees constantly rely on navigation and communication
- Making both navigation and communication handsfree would be a serious factor which will benefit those employees who constantly got to use mobile phones during their work.
- All working-class people also as people that enjoy journeying to foreign places on bike can find the smart helmet handy and reliable.

it proves to be technically possible.

2.3.2 Operational Feasibility:

Operation of the full model are typically achieved by exploitation the host controller (Raspberry Pi/Arduino), electrical actuators, sensors, controller circuit. Since the Voice model is utilized, there is no need to use the hand to manage the essential mobile functionalities.

2.3.3 Economic Feasibility:

The cost estimation of the project is much however the standard Google glasses, which can be used as a substitute for navigation whereas riding the bike. The project is calculable to hold overall worth around Rs.6000 to Rs.7500, that is type of low as compared to Google glasses that prices around Rs.95000. Also, Google glasses are not nevertheless out there in Bharat. The accuracy of the project is to boot high and therefore it proves to be economically possible. Maintenance value is significantly low since all its elements are open supply and simply designed.

VII. CONCLUSION AND FUTURE SCOPE

Hence, during this paper we've got with success mentioned the system and design style of the planned system. With the assistance of this device driving would become distraction

free, to associate oversize extent and folks can feel less urge to use their mobiles while driving. To some extent it can also stop potential accident situations. The developed style for the helmet reduces difficulties in traffic conditions and intends individuals to use this helmet for safety-driving. It's going to minimize the accident magnitude relation of distracted driving by creating all mobile functionalities out there to the user on voice command. By exploitation of this helmet, riders are going to be acutely aware, since they are giving voice commands to manage the essential bike functionalities. The planned system options a scope in everyday lives of people and working-class folks that use bikes as suggests that of travel. There are a lot of prospects of improvement within the system within the coming back future wherever several functionalities are typically intercalary into it, that provides it a colossal future scope. The planned system is feasible in several aspects like Economic, since prices lesser than product of same stature; Technical, since its elements are open supply, simply out there, problem free to put together and low cost; Operational, mutually module is capable of handling varied perform.

The sensible helmet is supposed to provide security, safety and luxury journey to the rider. The look of sensible helmet will show satisfactory results by additional modification in line with normal bioengineering and will work well by harvest home alternative energy. In future the helmet would be increased by applying AR (augmented reality) technology to provide onscreen navigation. In future the helmet would be increased by together with extra options like, alcohol detection and riders fatigue detection system, cooling mechanism, emergency alert system, phone charging unit and ignition management unit, that are lacked inside the traditional helmets to provide a much better safety and security to the rider.

ACKNOWLEDGMENT

With immense pleasure, we are presenting this Project report on "SMART HELMET" as part of the curriculum of B.E. Computer Engineering. We wish to thank all the people who gave us an unending support right from the stage the idea was conceived. We take this opportunity to convey our sincere thanks to our supportive Director of the Institute Dr. Sunil Ingole for his continual support and encouragement that made the Project a great success. We express our profound thanks to our respected Head of the Department, Dr. Priya Pise for her support and guidance throughout the course of our Project. We are grateful to our internal guide Dr. Poornashankar whose advice and valuable guidance helped us in making this Project interesting and successful. We also thank all those who have directly or indirectly guided and helped us in preparation of this Project. Last but not the least we thank our beloved parents, friends and well-wishers who helped us to do this Project by providing their kind help and assistance.

REFERENCES

- [1] M Uma, V Sneha, G Sneha, J Bhuvana, B Bharathi, "Formation of SQL from Natural Language Query using NLP", 2019 International Conference on Computational Intelligence in Data Science (ICCIDS)
- [2] Kwanrutai Nokkaew, Rachada Kongkachandra, "Keyphrase Extraction as Topic Identification Using Term Frequency and Synonymous Term Grouping", 2018 International Joint Symposium on Artificial Intelligence and Natural Language Processing (ISAI-NLP)
- [3] Sayanee Nanda, Harshada Joshi, Smita Khairmar, "An IOT Based Smart

System for Accident Prevention and Detection", 2018 Fourth International Conference on Computing Communication Control and Automation (ICCUBEA)

[4] Alexandru Cismas ; Ioana Matei ; Vlad Ciobanu ; George Casu, "Crash Detection Using IMU Sensors", 2017 21st International Conference on Control Systems and Computer Science (CSCS)

[5] Massimo Merenda; Demetrio Iero ; Francesco G. Della Corte, "Reconfigurable UHF RFID tag with sensing capabilities", 2019 IEEE International Conference on RFID Technology and Applications (RFID-TA)

[6] Abhishek Choudhary ; Deepak Sood ; Chander Charu Tripathi, "Wideband Long Range, Radiation Efficient Compact UHF RFID Tag", IEEE Antennas and Wireless Propagation Letters (Volume: 17 , Issue: 10 , Oct. 2018)

[7] Xiaolin Jia ; Miodrag Bolic ; Yuhao Feng ; Yajun Gu, "An Efficient Dynamic Anti-Collision Protocol for Mobile RFID Tags Identification", IEEE Communications Letters (Volume: 23 , Issue: 4 , April 2019)

[8] Hironori Wakana ; Masuyoshi Yamada ; Minoru Sakairi, "Portable Alcohol Detection System with Breath-Recognition Function", 2018 IEEE SENSORS

[9] Shahad Al-Youif Management & Science University, Faculty of Information science and Engineering, Malaysia; Musab A. M. Ali ; M. N. Mohammed, "Alcohol detection for car locking system", 2018 IEEE Symposium on Computer Applications & Industrial Electronics (ISCAIE)

[10] L. Velmurugan Jeppiaar Maamallan Engineering College, Department of Computer Science Engineering, Sriperumbudur, India; G. Raghuraj ; Judy Simon, "Google Glass Based GPS Navigation Using Smartwatch", 2017 IEEE International Conference on Computational Intelligence and Computing Research (ICCIC)

[11] Tapashee Tabassum Urmi Department of Computer Science and Engineering, Shahjalal University of Science and Technology, Sylhet, Sylhet-3114, Bangladesh; Jasmine Jahan Jammy; Sabir Ismail, "A corpus based unsupervised Bangla word stemming using N-gram language model", 2017 5th International Conference on Informatics, Electronics and Vision (ICIEV)

[12] Vikram Singh and Balwinder Saini, "an effective tokenization algorithm for information retrieval system", 2018 International Conference on Inventive Computation Technologies (ICICT)